



[www.insize.com](http://www.insize.com)

INSIZE



**ISHR-D121  
DIGITAL MAGNETIC ROCKWELL  
HARDNESS TESTER  
OPERATION MANUAL**



**Attention**

- ◆ This Instruction Manual shall be carefully read through in prior to use of the apparatus to clearly understand the detailed operation steps and special notes, and avoid apparatus damage or personal injury caused by improper use.

**Description**

- 1 Digital Magnetic Rockwell hardness tester applies computer, electric and sensor technology, realizing the high-accuracy and intelligence of portable tester, as well as the possibility of fast and accurate testing the body hardness of the large parts.
- 2 It simplifies the operation steps of Rockwell Hardness Test: directly load total test force; maintain it for a few seconds; release the total test force and then the test is finished, with no step of maintaining the preliminary test force of 10Kg.
- 3 It thoroughly follows the Rockwell Hardness Test Principle, and complies with relevant regulation of ISO6508, and ASTM E18.

**Principle and Structure**

- 1 The indenter is pressed (diamond cone or carbide ball ) into the specimen surface in two steps. After maintaining the pressure for a predetermined period of time, unload the major test force F1, and measure the remaining indentation depth h under initial test force F0.
- 2 Rockwell hardness value is:

$$HR=N - \frac{h}{S} \dots\dots\dots (1)$$

In this equation:

N — a constant related to scales; for A, C scales, N=100; for B scales, N=130.

S — unit indentation depth, for Rockwell hardness it is 0.002mm.

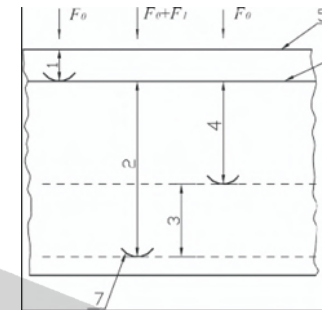

- 1 — indentation depth under initial test force F0;
- 2 — indentation depth under total test forces F0+F1;
- 3 — elastic recovery depth when major test force F1 is removed;
- 4 — remaining indentation depth h;
- 5 — test piece surface;
- 6 — datum plane;
- 7 — position of indenter

- 3 The tester consists of 2 magnetic chucks and 1 intelligent hardness test unit. In testing the magnetic chucks fixes the instrument to iron and steel part. The operator load test force by hand wheel, and the force sensor detects the force simultaneously and display it on screen, at the same time the distance sensor detects the depth which consists of fine screw and spiral encoder, then after the load force released and indenter uplifted for a suitable distance, the micro-processor will calculate the hardness and display it on screen.

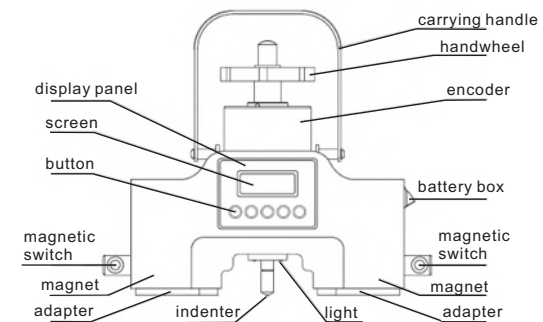

### Main Technical Parameters

Initial test force: 10kg  
 Test force: 30, 100, 150kg  
 Maximum magnetic force: 350kg  
 Force applying method: by screw  
 Indenter: 120°diamond cone, Ø1.588mm carbide balls  
 Testing Items: HRC, HRB, HRA  
 Resolution: 0.1HR  
 Accuracy: Meets the requirements of ISO6508/6506  
 Application: All metals, including steel, forged steel, cast iron, copper, copper alloy, aluminum, aluminum alloy and carbides etc.  
 Flat workpiece requirement: length>190mm, width>60mm, thickness>5mm  
 Cylinder or tube workpiece requirement: length>200mm, diameter>Ø50mm, wall thickness>8mm

### Panel And Screen

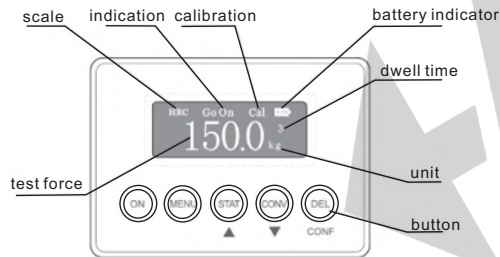

“ON”: Turn on and on the power. After 5 minutes the instruments without using, the power will be off automatically.

“MENU”: After pressing it, the instrument is on status setting and the menu displaying, then press "Manu" again, it would be on next level menu.

“STAT”: It’s a multi-functional button. On status of test, press it realizing the function of counting; on menu setting, it could move the arrow upward; on the status of calibration, it could increase values.

“CONV”: It’s a multi-functional button. On status of test, press it to see the conversion value; on menu setting, it could move the arrow down ward; on the status of calibration, it could decrease values.

“DEL”: It’s a double functional button. On status of test, it could delete current values; on status menu setting, it could confirm the selection and back to previous menu.

### Operation

- 1 Test Conditions:  
 Make sure the surface is flat and smooth. It is forbidden to have scale, decarburized layer, steel pit or dust on the surface of the part.  
**Note:**  
**Make sure the indenter is higher than the bottom surface before put the instrument on workpiece, the indenter can’t touch the test part. Otherwise, the indenter maybe crash to damaged.**
- 2 The tester should be attached to test part flatly and steadily with the indenter erected to the surface of test part. Turn the magnetic switch to "On", keeping the tester fixed onto the test part.
- 3 Power on the instrument, set the dwell time and select the test scale HRA, HRB or HRC. The scale will display on the screen.
- 4 Rotate the hand wheel to load test force steadily, observe the screen, stop or add test force extremely slowly when test force is close to the specified force. Try to keep the test force, now the time counting down displays on screen. When the time counting down finished, spin hand wheel reversely to release test force steadily until hardness values display. Then one full operation is accomplished.

Scale	Test force
HRA	60kg
HRB	100kg
HRC	150kg

**Notes:**

- a. Test force should be held until time values disappeared, otherwise the screen will display "Hold Not Enough".
- b. It is better to load the total test force once, without any pause.
- c. In releasing test force, "Go On" will display on screen when test force arrives at 0.0kg. The indenter should be upward until hardness values display.
- d. Please change another measuring point when overload.

### Calibration

- 1 Enter calibration mode and test 1st point and get the value, then there will be a symbol "?" flash 6 times.
- 2 Now test 2nd point after the symbol "?" flash 6 times, then make the third point.
- 3 The screen will display the average value of this three measurement, you can press the "STAT" and "CONV" buttons to adjust the value, at last press "DEL" to finish the calibration.

### Maintenance

- ◆ Tester should NOT be stocked in carry case for a long time.
- ◆ The bottom of adapter and iron seat should keep dry and clean, resistance of rust. Paint a little grease on the surface of adapter and iron seat if not operating for a long time.
- ◆ Do not forerake the tester, in case of damage to the screen.
- ◆ Pull out the battery from box in case of contaminating the tester by its weeping if it is predicted not to use for some time.  
It could be stocked outdoors in long time.
- ◆ Do not use water or detergent to clean it.
- ◆ Adapter is restricted to disassemble, except special adapters needed.
- ◆ Other parts are forbidden to disassemble without instruction and authority.