



www.insize.com

INSIZE



**ISHB-H131
HYDRAULIC BRINELL
HARDNESS TESTER
OPERATION MANUAL**



Introduction

ISHB-H131 Hydraulic Brinell hardness tester has the same structure as King Brinell hardness tester. It is the unique portable hardness tester in the world which applies test condition with 3000kg test force on a 10mm carbide indenter. The large indentation resulted by the tester can reflect the average value of combined influence affected by all the compositions of large materials. It is unaffected by certain composition of materials or partial nonuniform distribution and very suitable for testing nonuniform materials made of large crystal particle. The testing result of this instrument is true and accurate with good repeatability and it has a good correspondence with tensile strength. It is the best mechanical property tester which can be used on site. The test condition and accuracy meet the requirements of ISO 6506 and ASTM E110 and can be used to test rough castings, forgings, nonferrous metals and semi-finished products after tempering heat treatment.

Features

1 On-site testing, without sampling

It is a portable instrument suitable to use in the plant. It is easy to operate and convenient to carry. So it can be used to test the large workpiece, fixed workpiece without sampling and to test the large workpiece in any direction (like upside, underside, side face or inversion) on site.

2 Permanent indentation, easy reinspection

By applying 3000kg test force and 10mm ball indenter, the permanent indentation can be reinspected at any time after testing. In addition, the existence of the indentation shows that the workpiece has been tested.

3 Accurate testing, real result

Testing according to the real principle of Brinell hardness testing, ISHB-H131 applies the same principle as the bench type Brinell hardness tester. Thus the result is totally different from the

inaccurate conversion value that other portable hardness testers (eg. Leeb hardness tester) get. The calibration accuracy of the test force is 0.5%. The accuracy of hardness testing is the same as bench type hardness tester.

4 Optional test condition, wide testing range

The tester has various testing forces and indenters so that it can test all kinds of materials and its testing range can be up to 16-650HBW.

5 High technique, high cost performance

The parts machining and assembling quality of this instrument are much better than King Brinell hardness tester. It is free of the problem of oil leak of the hydraulic system and gear jamming of the jacking system, so it has a higher cost performance.

Technical Parameters

Test Force:3000kg

Indenter:10mm carbide ball indenter

Testing Range:16-650HBW

Max. Specimen Height:350mm Throat Depth:100mm

Error Indication and Repeatability:comply with ISO 6506\

Net Weight:13.8kg

Principle & Structures

It adopts hydraulic principle which functions the hand-operated way to apply 3000kg test force. The central part of ISHB-H131 is a small hydraulic system in which a release valve is used to control the test force. When the force reaches 3000kg, the release valve will open and the pressure will fall down. As specified in the operation manual, the tester needed to be forced to make the indicator of the dial point at 3000kg test force for 3-5 times. Thus it is equivalent to the test condition of Brinell hardness testing method to hold 3000kg test force for 10-15 seconds with 10mm steel ball, which complies with ASTM E110.

The structure of the instrument is shown as below:

- 1 Jacking system
- 2 Pressure release valve
- 3 Control valve
- 4 Cylinder cap
- 5 Hydraulic pump
- 6 Crank
- 7 Handle
- 8 Gauge
- 9 Handle
- 10 Screw rod
- 11 Operating lever
- 12 Carriage
- 13 Test head
- 14 Screw
- 15 Indenter body
- 16 Indenter holder
- 17 Ball
- 18 Anvil cap
- 19 Anvil
- 20 Base

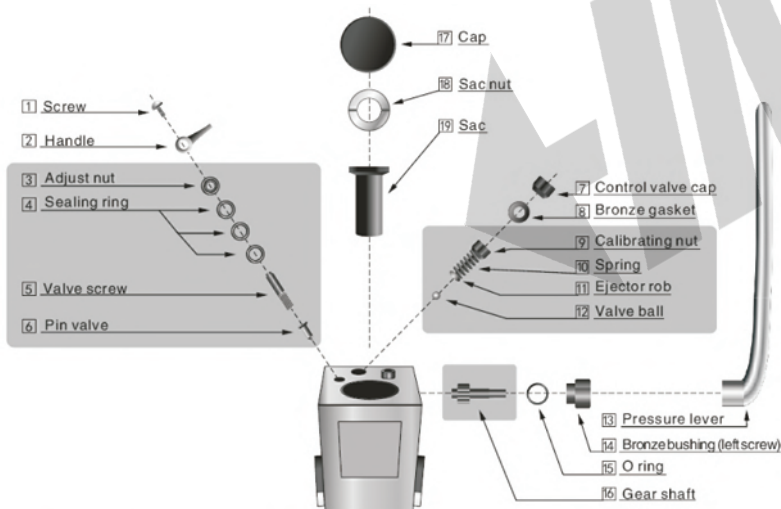
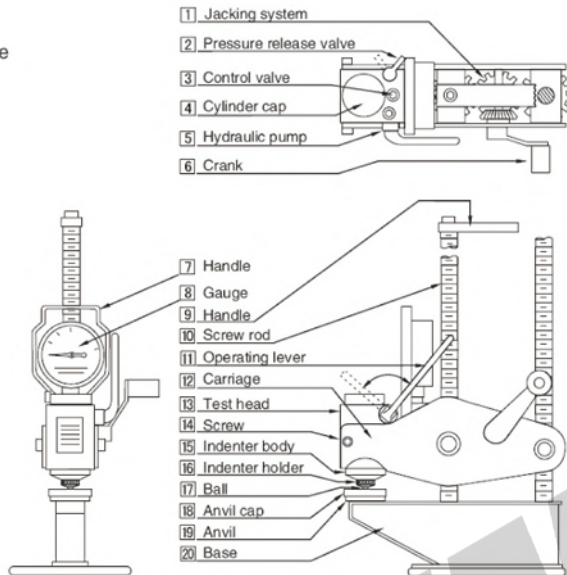

Note: The parts displayed in gray zone can not be removed by the user.

The carriage is composed of base, anvil, anvil holder, throat, handle, jacking system and test head pallet. The base with anvil applies the extended structure in front, which is easy to clamp workpieces or to test tubes. The test head installed between the two pallets and the throat is responsible for holding the tester and keeping the 3000kg test force. The screw jacking system controlled by the crank can be up and down from the throat in order to make the test head move.

The test head is composed of gauge, pressure lever, indenter, oil cylinder, pressure release lever and operating lever.

The test head is a small hydraulic system. By giving the small cylinder a little force, the large cylinder (indenter) will produce a huge force. The function of the dial gauge is to show the value of test force the pressure lever is used to apply the force; the indenter is to apply the force onto the workpiece and result in a standard Brinell indentation on it. The job of the oil cylinder is to store oil, pressure release lever is used to control the test force releasing or keeping, and operating lever is used to accurately control the largest 3000kg test force.

The test head is installed on the carriage in order to move the test head up and down by means of screw jacking system.

Operation

1 Prepare the workpiece

Choose an appropriate part of the sample and clean the rust and dirt around the test point before testing. If the surface of the sample is rough or has the coating, hardened layer, and decarburized layer, the operator need to polish the surface of the workpiece properly until the substrate part of the workpiece exposes. The high quality rechargeable grinder can be bought from the manufacturer.

2 Calibration of the tester

The calibration accuracy of the tester has been verified before delivery. A calibration certificate is attached to the tester. Because of the wrong operation or delivery accident, the accuracy of the tester will be impacted so that it will influence the testing result.

Before using the tester, inspect the accuracy of the tester with the test block. In order to assure the accuracy of the tester, it is necessary to inspect the tester regularly with test blocks.

According to the rule, the loading force time is 3-5 times when test the steel workpiece. Decrease the loading time when test the hard metal; Add the loading time when test the soft metal. Determine the most correct loading time before test the standard hardness block, this data can be used for reference when test similar specimen in the future.

3 Select and install the anvil

The standard package of the tester includes 3 anvils. Each anvil fits for certain specimens.

The flat anvil fits for most specimens and test blocks; the V anvil is used to test cylinder and convex specimens; the dome anvil is used to test the concave surfaces and tubes.

Selecting the correct anvil can avoid unstable force loading and assure the accuracy and reliability of the test.

4 Check the indenter

Check the indenter before testing and make sure the indenter holder is fastened tightly, otherwise it may damage the indenter ball or make it lost.

5 Check the indenter

Check the indenter before testing and make sure the indenter holder is fastened tightly, otherwise it may damage the indenter ball or make it lost.

6 Install the pressure lever and open the pressure release lever, then raise the test head in enough height, remove the anvil cap.

7 Test:

Put the specimen in the opening of the tester; turn the crank in order to make the test head move down and clamp the specimen between the test head and the anvil. Keep turning the crank with big loading force in order to make the indenter body come into the test head body. Then close the pressure release lever and move the pressure lever; load the test force on the specimen and watch the gauge. The dial begins to move to 3000kg scale. Continue to move the pressure lever. When the dial reaches 3000kg, the control valve will work and the pressure will fall down. Repeat this

procedure 2-4 times and make the dial point reach 3000kg for 2-4 times (totally reaches 3000kg for 3-5 times). Then the progress of loading force is finished. Open the pressure release lever, raise the test head and move the tester away from the specimen. The indenter will leave an indentation on the surface of the specimen. Use the reading microscope to measure the diameter of the indentation. Check the tables in the appendix for Brinell hardness test results, If there is provisionally no need of testing, do as the following processes to protect the tester:

a. Install the anvil cap.

b. Lower the test head and make the indenter reach the anvil cap.

c. Remove the pressure lever.

8 Measuring the indentation

Look into the ocular and turn the rotational barrel dial to make the vertical lens line aligned with the "0" scale of the horizontal line, Meanwhile look at the barrel outside, the long black scale mark should rest on "0" scale of the rotational drum dial.

Put the reading microscope on the test piece to locate the indentation in the center of the viewing field of the microscope. Move the microscope to make the vertical line tangential to the left edge of the indentation. Press the bottom of the reading microscope firmly, turn the rotational drum dial and make the vertical line tangential to the right edge of the indentation.

Add the integer part (mm) of the indentation diameter from the horizontal scale mark, then read the 2-digit decimal part of the indentation diameter from the rotational drum, accurate to 0.01mm.

Routine use, when you look into the ocular, let the vertical line is aligned with the "0" scale mark of the horizontal line, but in the outside barrel if the "0" scale mark of the rotational drum dial does not align with the long black scale mark, it means the microscope is inaccurate. Adjustment should be made as follow:

a. Make the vertical lens line aligned with the "0" scale mark of the horizontal line.

b. Loosen the three screws on the rotational drum dial.

c. Make the "0" scale mark on rotational drum dial exactly aligned with the long reading mark.

d. Fasten the three screws.

Maintenance

Some parts of the tester may wear after long time use, for example, seals leakage, difficulty in loading full scales force, inaccurate test result, and difficulty in retracting the indenter, deformed or worn indenter, loose support frame, being out of gauge and so on. If these problems occur, the tester needs to be repaired.

Some of the maintenance tasks must to be done by the manufacturer. If the tester is damaged or broken, send it back to the manufacturer.

Some of the maintenance tasks should be done by the resellers. The manufacturer will have training for the technical team of main resellers to make them professional to calibrate the tester, change oil or accomplish some of the maintenance work. The user can repair their testers at the nearest retailer.

Other maintenance tasks can be accomplished by the user. Because of location or transportation limitation, some end users can not send the tester back to manufacturer or distributor. The user who has professional technician can do by himself to change oil, calibrate tester and repair the seals according to the maintenance manual. If there is any difficulty during the repairing, contact the manufacturer for support. Parts and tools for changing oil can be bought from the manufacturer.

As a general rule, the parts taken off during repairing should be changed to new ones. The repeated use of the old ones will affect the performance of the tester, especially for the O ring, washer and screw. Problems and handling:

① Hard to load test force:

If it is hard for the test force to reach full scale of 3000kg, the probable cause and handling is as following:

1.1. Indenter over-extending

When the indenter is extending too long, the pressure lever will take effect; the movement distance of the indenter can not be long enough to apply 3000kg test force on the specimen.

The handling method is:

Open the release valve, turn the crank and force the indenter to retract into the test head body.

1.2. Oil shortage

After long time use, the hydraulic oil will lose and the remaining volume is not enough to produce proper movement of indenter, so that it can not apply full scale of 3000kg test force on the specimen.

Checking the hydraulic sump

Take off the pressure lever and check if there is oil near the bronze bushing. If there is, it means the O-ring in the bronze bushing is worn. Both of the O ring and the bushing need to be changed for new ones. The operation process of it is as following: Take off the test head from the carriage, make the sump upside and put it on the desk. During this process, take care to avoid oil leakage.

Use the special wrench for bronze bushing to take the bronze bushing off. The bronze bushing has a left-hand thread which is different from other threads, so turn it clockwise. An O ring will be found in the bronze bushing. If the O ring wears, some oil will leak from bronze bushing. Fill the hydraulic sump with oil, take off the worn O ring, insert a new one and screw tightly. There will be some hydraulic oil overflowing around the bronze bushing. Clean the test head with soft cloth and cleaning fluid and install back the test head.

Other parts of the hydraulic sump can not be taken down or changed except for bronze bushing and o ring.

Changing hydraulic oil

To use oil of correct type and viscosity is vital important. Mobile oil BB is the best (Saybolt 956 Secs at 100°F) and it can be bought locally. The spare hydraulic oil and the tools for changing the oil can be bought from manufacturer or retailer.

The procedures of changing oil are a little complicated, change the oil strictly following the instruction. Any disoperation may result in permanent damage of the parts. Procedures are as following:

Close the pressure release lever, move the handle and push the indenter out to 10-12mm.

Screw off the cap and use the special wrench to take off the sac

nut under the cap, and then take out the sac.

Open the pressure release valve. Turn the crank in order to make the whole indenter come into the test head body.

Close the pressure release lever.

Remove the screws which are fixed on the carriage.

Remove the test head, dump the old oil from the cylinder and then put the test head back on the carriage.

Fix the test head in the carriage and tighten the screws.

Fill sump with oil, align the oil level with the step of the cylinder.

Turn the pressure lever and push the indenter out. At this moment, the oil level will fall down. During the operation, keep the oil level and the step at the same level all the time. Add the oil while pushing out the indenter until the exposing part of indenter is 10-12mm.

Pump the 1/2 oil out of the sump with the injector.

Put back the sac. If there is some oil spilling from the sac, it means that the cylinder is full. If there is no spilling oil, take out the sac and add more oil again.

Quickly insert and fasten the sac nut tightly. Cover the cap and fasten it. Open the pressure release lever.

Turn the crank and push in the indenter totally come into the test body.

Close the pressure release lever. Load test force to 3000kg. Open the pressure release lever.

Repeat the above processes for 5-10 times. It can get rid of the air which gets inside during changing oil in hydraulic system.

Clean the test head and carriage with soft cloth cleaning fluid and then reassemble test head.

Verification of test head

If it is difficult to load test force during a short time after changing oil, that indicates X ring may wear. X ring can not be changed by the user.

They must be sent back to the manufacturer for maintenance.

② Instrument misalignment

The tester may be inaccurate after long time use. It shows that the readings will be out of specified range when testing on the standard test block.

Probable reasons and handling:

2.1 Incorrect numbers of loadings

To be equivalent to the condition for Brinell hardness test method of holding 3000kg test force for 10-15 seconds with 10mm indenter. The tester is ruled to be forced for 3-5 times to make 3000kg. If the tester is a little out of tolerance, add 1 or 2 more times for loading force so that it can make readings approaching to the real readings.

Add the loading times when test the soft metal. For example, when applying 500kg test force with 10mm ball, the loading force times need to be added to 10-15 times.

2.2 Expired block

The block has been inspected before leaving factory and the hardness value marks on the front face of block as well as its inspection date is on the certificate. The valid period of blocks is one year and it should be rechecked after one year otherwise the hardness value is not reliable, and the tester calibrated with the expired block will be inaccurate. New test blocks can be bought from the manufacturer.

2.3 Deformed and worn ball

The carbide ball is durable and hard with high accurate dimension. After a long time use and the wrong operation or testing on hard materials, the ball may become deformed or worn.

When the tester is inaccurate and the block is verified to be not the reason, remove the ball and twirl the ball in order to change its testing surface, then reinstall it on the test head and fasten the ball cover.

It may take several times to renew the testing surface in one ball. After too many times of the renewal, the ball cannot be used again and needs to be changed for a new one. New balls can be bought from the manufacturer.

2.4 Inaccurate test force

After eliminating the reasons of blocks and balls, the accuracy of 3000kg test force can be the probable reason.

The 3000kg test force has been calibrated before leaving factory and its tolerance is less than $\pm 0.5\%$ of 3000kg.

The 3000kg test force is controlled by the control valve. If the 3000kg test force needs to be recalibrated, follow the steps below. First, turn the pressure lever in order to make the indenter extending as far as possible. Second, use an Allen wrench to remove the control valve cover and take off the copper gasket, then oil will be seen through the hole of control lever, and a calibrating screw is underneath. Use straight screwdriver to search for the calibrating screw under the oil and turn it a little (any direction is ok). If the hardness is a little higher, turn the calibrating screw clockwise; otherwise, turn the calibrating screw anticlockwise. Make sure the angle turned is not too big otherwise it is hard to find the original calibrating point and the test force may be out of the secure range and the tester may be damaged.

After adjusting the screw for control valve, verify the tester with the test block. If it is out of tolerance, repeat the processes above until it is accurate.

After adjustment, fill the hole with oil. Replace the copper gasket with a new one and screw the cover tightly.

The screw for control valve can be adjusted only a little. Too much adjustment and taking it off are not allowed.

Other reasons for being out of tolerance, please contact manufacturer.

3 Leakage of pressure release valve

There are three sac rings in the pressure release valve for sealing. The sealing rings will be damaged after long time use which makes the sealing effect worse, and oil will leak slightly. Check the pressure release lever during the testing. If there is a little oil leaking from the lever, do as the following processes:

Firstly, turn the pressure lever to make the indenter extending as far as possible. Secondly, remove the screws of the pressure release lever with a screwdriver and take off the crank. There will be a nut beneath it. Use the wrench for pressure release lever to screw the nut, turn clockwise 1/6-1/8 round. Fill the hole with oil and reinstall the pressure release handle and fasten it with screw.

The maintenance of pressure release valve are limited to the above procedures. The release nut can not be removed by the user.

Brinell Hardness Table

Ball Diameter D/mm		0.102xF/D ²			
		30	15	10	5
		Test Force F/N (kg)			
10	5	29.42kN (3000) 7.355kN (750)	14.71kN (1500)	9.807kN (1000)	4.903kN (500)
Indentation Diameter D/mm		Brinell Hardness (HBW)			
2.40	1.200	653	327	218	109
2.41	1.205	648	324	216	108
2.42	1.210	643	321	214	107
2.23	1.215	637	319	212	106
2.44	1.220	632	316	211	105
2.45	1.225	627	313	209	104
2.46	1.230	621	311	207	104
2.47	1.235	616	308	205	103
2.48	1.240	611	306	204	102
2.49	1.245	606	303	202	101
2.50	1.250	601	301	200	100
2.51	1.255	597	298	199	99.4
2.52	1.260	592	296	197	98.6
2.53	1.265	587	294	196	97.8
2.54	1.270	582	294	194	97.1
2.55	1.275	578	289	193	96.3
2.56	1.280	573	287	191	95.5
2.57	1.285	569	284	190	94.8
2.58	1.290	564	282	188	94.0
2.59	1.295	560	280	187	93.3
2.60	1.300	555	278	185	92.6
2.61	1.305	551	276	184	91.8
2.62	1.310	547	273	182	91.1
2.63	1.315	543	271	181	90.4
2.64	1.320	538	269	179	89.7
2.65	1.325	534	267	178	89.0
2.66	1.330	530	265	177	88.4
2.67	1.335	526	263	175	87.7
2.68	1.340	522	261	174	87.0
2.69	1.345	518	259	173	86.4
2.70	1.350	514	257	171	85.7
2.71	1.355	510	255	170	85.1
2.72	1.360	507	253	169	84.4
2.73	1.365	503	251	168	83.8
2.74	1.370	499	250	166	83.2
2.75	1.375	495	248	165	82.6
2.76	1.380	492	246	164	81.9
2.77	1.385	488	244	163	81.3
2.78	1.390	485	242	162	80.8
2.79	1.395	481	240	160	80.2
2.80	1.400	477	239	159	79.6
2.81	1.405	474	237	158	79.0
2.82	1.410	471	235	157	78.4
2.83	1.415	467	234	156	77.9
2.84	1.420	464	232	155	77.3

Ball Diameter D/mm		0.102x F/D^2			
		30	15	10	5
		Test Force F/N (kg)			
10	5	29.42kN (3000) 7.355kN (750)	14.71kN (1500)	9.807kN (1000)	4.903kN (500)
Indentation Diameter D/mm		Brinell Hardness (HBW)			
2.85	1.425	461	230	154	76.8
2.86	1.430	457	229	152	76.2
2.87	1.435	454	227	151	75.7
2.88	1.440	451	225	150	75.1
2.89	1.445	448	224	149	74.6
2.90	1.450	444	222	148	74.1
2.91	1.455	441	221	147	73.6
2.92	1.460	438	219	146	73.0
2.93	1.465	435	218	145	72.5
2.94	1.470	432	216	144	72.0
2.95	1.475	429	215	143	71.5
2.96	1.480	426	213	142	71.0
2.97	1.485	423	212	141	70.5
2.98	1.490	420	210	140	70.1
2.99	1.495	417	209	139	69.6
3.00	1.500	415	207	138	69.1
3.01	1.505	412	206	137	68.6
3.02	1.510	409	205	136	68.2
3.03	1.515	406	203	135	67.7
3.04	1.520	404	202	135	67.3
3.05	1.525	401	200	134	66.8
3.06	1.530	398	199	133	66.4
3.07	1.535	395	198	132	65.9
3.08	1.540	393	196	131	65.5
3.09	1.545	390	195	130	65.0
3.10	1.550	388	194	129	64.6
3.11	1.555	385	193	128	64.2
3.12	1.560	383	191	128	63.8
3.13	1.565	380	190	127	63.3
3.14	1.570	378	189	126	62.9
3.15	1.575	375	188	125	62.5
3.16	1.580	373	186	124	62.1
3.17	1.585	370	185	123	61.7
3.18	1.590	368	184	123	61.3
3.19	1.595	366	183	122	60.9
3.20	1.600	363	182	121	60.5
3.21	1.605	360	180	120	60.1
3.22	1.610	359	179	120	59.8
3.23	1.615	356	178	119	59.4
3.24	1.620	354	177	118	59.0
3.25	1.625	352	176	117	58.6
3.26	1.630	350	175	117	58.3
3.27	1.635	347	174	116	57.9
3.28	1.640	345	173	115	57.5
3.29	1.645	343	172	114	57.2

Ball Diameter D/mm		0.102x F/D^2			
		30	15	10	5
		Test Force F/N (kg)			
10	5	29.42kN (3000) 7.355kN (750)	14.71kN (1500)	9.807kN (1000)	4.903kN (500)
Indentation Diameter D/mm		Brinell Hardness (HBW)			
3.30	1.650	341	170	114	56.8
3.31	1.655	339	169	113	56.5
3.32	1.660	337	168	112	56.1
3.33	1.665	335	167	112	55.8
3.34	1.670	333	166	111	55.4
3.35	1.675	331	165	110	55.1
3.36	1.680	329	164	110	54.8
3.37	1.685	326	163	109	54.4
3.38	1.690	325	162	108	54.1
3.39	1.695	323	161	108	53.8
3.40	1.700	321	160	107	53.4
3.41	1.705	319	159	106	53.1
3.42	1.710	317	158	106	52.8
3.43	1.715	315	157	105	52.5
3.44	1.720	313	156	104	52.2
3.45	1.725	311	156	104	51.8
3.46	1.730	309	155	103	51.5
3.47	1.735	307	154	102	51.2
3.48	1.740	306	153	102	50.9
3.49	1.745	304	152	101	50.6
3.50	1.750	302	151	101	50.3
3.51	1.755	300	150	100	50.0
3.52	1.760	298	149	99.5	49.7
3.53	1.765	297	148	98.9	49.4
3.54	1.770	295	147	98.3	49.2
3.55	1.775	293	147	97.7	48.9
3.56	1.780	292	146	97.2	48.6
3.57	1.785	290	145	96.6	48.3
3.58	1.790	288	144	96.1	48.0
3.59	1.795	286	143	95.5	47.7
3.60	1.800	285	142	95.0	47.5
3.61	1.805	283	142	94.4	47.2
3.62	1.810	282	141	93.9	46.9
3.63	1.815	280	140	93.3	46.7
3.64	1.820	278	139	92.8	46.4
3.65	1.825	277	138	92.3	46.1
3.66	1.830	275	138	91.8	45.9
3.67	1.835	274	137	91.2	45.6
3.68	1.840	272	136	90.7	45.4
3.69	1.845	271	135	90.2	45.1
3.70	1.850	269	135	89.7	44.9
3.71	1.855	268	134	89.2	44.6
3.72	1.860	266	133	88.7	44.4
3.73	1.865	265	132	88.2	44.1
3.74	1.870	263	132	87.7	43.9

Ball Diameter D/mm		0.102xF/D ²			
		30	15	10	5
		Test Force F/N (kg)			
10	5	29.42kN (3000) 7.355kN (750)	14.71kN (1500)	9.807kN (1000)	4.903kN (500)
Indentation Diameter D/mm		Brinell Hardness (HBW)			
3.75	1.875	262	131	87.2	43.6
3.76	1.880	260	130	86.8	43.4
3.77	1.885	259	129	86.3	43.1
3.78	1.890	257	129	85.8	42.9
3.79	1.895	256	128	85.3	42.7
3.80	1.900	255	127	84.9	42.4
3.81	1.905	253	127	84.4	42.2
3.82	1.910	252	126	83.9	42.0
3.83	1.915	250	125	83.5	41.7
3.84	1.920	249	125	83.0	41.5
3.85	1.925	248	124	82.6	41.3
3.86	1.930	246	123	82.1	41.1
3.87	1.935	245	123	81.7	40.9
3.88	1.940	244	122	81.3	40.6
3.89	1.945	242	121	80.8	40.4
3.90	1.950	241	121	80.4	40.2
3.91	1.955	240	120	80.0	40.0
3.92	1.960	239	119	79.5	39.8
3.93	1.965	237	119	79.1	39.6
3.94	1.970	236	118	78.7	39.4
3.95	1.975	235	117	78.3	39.1
3.96	1.980	234	117	77.9	38.9
3.97	1.985	232	116	77.5	38.7
3.98	1.990	231	116	77.1	38.5
3.99	1.995	230	115	76.7	39.3
4.00	2.000	229	114	76.3	38.1
4.01	2.005	228	114	75.9	37.9
4.02	2.010	226	113	75.5	37.7
4.03	2.015	225	113	75.1	37.5
4.04	2.020	224	112	74.7	37.3
4.05	2.025	223	111	74.3	37.1
4.06	2.030	222	111	73.9	37.0
4.07	2.035	221	111	73.5	36.8
4.08	2.040	216	110	73.2	36.6
4.09	2.045	218	109	72.8	36.4
4.10	2.050	217	109	72.4	36.2
4.11	2.055	216	108	72.0	36.0
4.12	2.060	215	108	71.7	35.8
4.13	2.065	214	107	71.3	35.7
4.14	2.070	213	106	71.0	35.5
4.15	2.075	212	106	70.6	35.3
4.16	2.080	211	105	70.2	35.1
4.17	2.085	210	105	69.9	34.9
4.18	2.090	209	104	69.5	34.8
4.19	2.095	208	104	69.2	34.6

Ball Diameter D/mm		0.102xF/D ²			
		30	15	10	5
		Test Force F/N (kg)			
10	5	29.42kN (3000) 7.355kN (750)	14.71kN (1500)	9.807kN (1000)	4.903kN (500)
Indentation Diameter D/mm		Brinell Hardness (HBW)			
4.20	2.100	207	103	68.8	34.4
4.21	2.105	205	103	68.5	34.2
4.22	2.110	204	102	68.2	34.1
4.23	2.115	203	102	67.8	33.9
4.24	2.120	202	101	67.5	33.7
4.25	2.125	201	101	67.1	33.6
4.26	2.130	200	100	66.8	33.4
4.27	2.135	199	99.7	66.5	33.2
4.28	2.140	198	99.2	66.2	33.1
4.29	2.145	198	98.8	65.8	32.9
4.30	2.150	197	98.3	65.5	32.8
4.31	2.155	196	97.8	65.2	32.6
4.32	2.160	195	97.3	64.9	32.4
4.33	2.165	194	96.8	64.6	32.3
4.34	2.170	193	96.4	64.2	32.1
4.35	2.175	192	95.9	63.9	32.0
4.36	2.180	191	95.4	63.6	31.8
4.37	2.185	190	95.0	63.3	31.7
4.38	2.190	189	94.5	63.0	31.5
4.39	2.195	188	94.1	62.7	31.4
4.40	2.200	187	93.6	62.4	31.2
4.41	2.205	186	93.2	62.1	31.1
4.42	2.210	185	92.7	61.8	30.9
4.43	2.215	185	92.3	61.5	30.8
4.44	2.220	184	91.8	61.2	30.6
4.45	2.225	183	91.4	60.9	30.5
4.46	2.230	182	91.0	60.6	30.3
4.47	2.235	181	90.6	60.4	30.2
4.48	2.240	180	90.1	60.1	30.0
4.49	2.245	179	89.7	59.8	29.9
4.50	2.250	179	89.3	59.5	29.8
4.51	2.255	178	88.9	59.2	29.6
4.52	2.260	177	88.4	59.0	29.5
4.53	2.265	176	88.0	58.7	29.3
4.54	2.270	175	87.6	58.4	29.2
4.55	2.275	174	87.2	58.1	29.1
4.56	2.280	174	86.8	57.9	28.9
4.57	2.285	173	86.4	57.6	28.8
4.58	2.290	172	86.0	57.3	28.7
4.59	2.295	171	85.6	57.1	28.5
4.60	2.300	170	85.2	56.8	28.4
4.61	2.305	170	84.8	56.5	28.3
4.62	2.310	169	84.4	56.3	28.1
4.63	2.315	168	84.0	56.0	28.0
4.64	2.320	167	83.6	55.8	27.9

Ball Diameter D/mm		0.102x F/D^2			
		30	15	10	5
		Test Force F/N (kg)			
10	5	29.42kN (3000) 7.355kN (750)	14.71kN (1500)	9.807kN (1000)	4.903kN (500)
Indentation Diameter D/mm		Brinell Hardness (HBW)			
4.65	2.325	167	83.3	55.5	27.8
4.66	2.330	166	82.9	55.3	27.6
4.67	2.335	165	82.5	55.0	27.5
4.68	2.340	164	82.1	54.8	27.4
4.69	2.345	124	81.8	54.5	27.3
4.70	2.350	163	81.4	54.3	27.1
4.71	2.355	162	81.0	54.3	27.0
4.72	2.360	161	80.7	53.8	26.9
4.73	2.365	161	80.3	53.5	26.8
4.74	2.370	160	79.9	53.3	26.6
4.75	2.375	159	79.6	53.0	26.5
4.76	2.380	158	79.2	52.8	26.4
4.77	2.385	158	78.9	52.6	26.3
4.78	2.390	157	78.5	52.3	26.2
4.79	2.395	156	78.2	52.1	26.1
4.80	2.400	156	77.8	51.9	25.9
4.81	2.405	155	77.5	51.6	25.8
4.82	2.410	154	77.1	51.4	25.7
4.83	2.415	154	76.8	51.2	25.6
4.84	2.420	153	76.4	51.0	25.5
4.85	2.425	152	76.1	50.7	25.4
4.86	2.430	152	75.8	50.5	25.3
4.87	2.435	151	75.4	50.3	25.1
4.88	2.440	150	75.1	50.1	25.0
4.89	2.445	150	74.8	49.8	24.9
4.90	2.450	149	74.4	49.6	24.8
4.91	2.455	148	74.1	49.4	24.7
4.92	2.460	148	73.8	49.2	24.6
4.93	2.465	147	73.5	49.0	24.5
4.94	2.470	146	73.2	48.8	24.4
4.95	2.475	146	72.8	48.6	24.3
4.96	2.480	145	72.5	48.3	24.2
4.97	2.485	144	72.2	48.1	24.1
4.98	2.490	144	71.9	47.9	24.0
4.99	2.495	143	71.6	47.7	23.9
5.00	2.500	143	71.3	47.5	23.8
5.01	2.505	142	71.0	47.3	23.7
5.02	2.510	141	70.7	47.1	23.6
5.03	2.515	141	70.4	46.9	23.5
5.04	2.520	140	70.1	46.7	23.4
5.05	2.525	140	69.8	46.5	23.3
5.06	2.530	139	69.5	46.3	23.2
5.07	2.535	138	69.2	46.1	23.1
5.08	2.540	138	68.9	45.9	23.0
5.09	2.545	137	69.6	45.7	22.9

Ball Diameter D/mm		0.102x F/D^2			
		30	15	10	5
		Test Force F/N (kg)			
10	5	29.42kN (3000) 7.355kN (750)	14.71kN (1500)	9.807kN (1000)	4.903kN (500)
Indentation Diameter D/mm		Brinell Hardness (HBW)			
5.10	2.550	137	68.3	45.5	22.8
5.11	2.555	136	68.0	45.3	22.7
5.12	2.560	135	67.7	45.1	22.6
5.13	2.565	135	67.4	45.0	22.5
5.14	2.570	134	67.1	44.8	22.4
5.15	2.575	134		44.6	22.3
5.16	2.580	133	66.9	44.4	22.2
5.17	2.585	133	66.6	44.2	22.1
5.18	2.590	132	66.3	44.0	22.0
5.19	2.595	132	65.8	43.8	21.9
5.20	2.600	131	65.5	43.7	21.8
5.21	2.605	130	65.2	43.5	21.7
5.22	2.610	130	64.9	43.3	21.6
5.23	2.615	129	64.7	43.1	21.6
5.24	2.620	129	64.4	42.9	21.5
5.25	2.625	128	64.1	42.8	21.4
5.26	2.630	128	63.9	42.6	21.3
5.27	2.635	127	63.6	42.4	21.2
5.28	2.640	127	63.3	42.2	21.1
5.29	2.645	126	63.1	42.1	21.0
5.30	2.650	126	62.8	41.9	20.9
5.31	2.655	125	62.6	41.7	20.9
5.32	2.660	125	62.3	41.5	20.8
5.33	2.665	124	62.1	41.4	20.7
5.34	2.670	124	61.8	41.2	20.6
5.35	2.675	123	61.5	41.0	20.5
5.36	2.680	123	61.3	40.9	20.4
5.37	2.685	122	61.0	40.7	20.3
5.38	2.690	122	60.8	40.5	20.3
5.39	2.695	121	60.6	40.4	20.2
5.40	2.700	121	60.3	40.2	20.1
5.41	2.705	120	60.1	40.0	20.0
5.42	2.710	120	59.8	39.9	19.9
5.43	2.715	119	59.6	39.7	19.9
5.44	2.720	119	59.3	39.6	19.8
5.45	2.725	118	59.1	39.4	19.7
5.46	2.730	118	58.9	39.2	19.6
5.47	2.735	117	58.6	39.1	19.5
5.48	2.740	117	58.4	38.9	19.5
5.49	2.745	116	58.2	38.8	19.4
5.50	2.750	116	57.9	38.6	19.3
5.51	2.755	115	57.7	38.5	19.2
5.52	2.760	115	57.5	38.3	19.2
5.53	2.765	114	57.2	38.2	19.1
5.54	2.770	114	57.0	38.0	19.0

Ball Diameter D/mm		0.102xF/D ²			
		30	15	10	5
		Test Force F/N (kg)			
10	5	29.42kN (3000) 7.355kN (750)	14.71kN (1500)	9.807kN (1000)	4.903kN (500)
Indentation Diameter D/mm		Brinell Hardness (HBW)			
5.55	2.775	114	56.9	37.9	18.9
5.56	2.780	113	56.6	37.7	18.9
5.57	2.785	113	56.3	37.6	18.8
5.58	2.790	112	56.1	37.4	18.7
5.59	2.795	112	55.9	37.3	18.6
5.60	2.800	111	55.7	37.1	18.6
5.61	2.805	111	55.5	37.0	18.5
5.62	2.810	110	55.2	36.8	18.4
5.63	2.815	110	55.0	36.7	18.3
5.64	2.820	110	54.8	36.5	18.3
5.65	2.825	109	54.6	36.4	18.2
5.66	2.830	109	54.4	36.3	18.1
5.67	2.835	108	54.2	36.1	18.1
5.68	2.840	108	54.0	36.0	18.0
5.69	2.845	107	53.7	35.8	17.9
5.70	2.850	107	53.5	35.7	17.8
5.71	2.855	107	53.3	35.6	17.8
5.72	2.860	106	53.1	35.4	17.7
5.73	2.865	106	52.9	35.3	17.6
5.74	2.870	105	52.7	35.1	17.6
5.75	2.875	105	52.5	35.0	17.5
5.76	2.880	105	52.3	34.9	17.4
5.77	2.885	104	52.1	34.7	17.4
5.78	2.890	104	51.9	34.6	17.3
5.79	2.895	103	51.7	34.5	17.2
5.80	2.900	103	51.5	34.3	17.2
5.81	2.905	103	51.3	34.2	17.1
5.82	2.910	102	51.1	34.1	17.0
5.83	2.915	102	50.9	33.9	17.0
5.84	2.920	101	50.7	33.8	16.9
5.85	2.925	101	50.5	33.7	16.8
5.86	2.930	101	50.3	33.6	16.8
5.87	2.935	100	50.2	33.4	16.7
5.88	2.940	99.9	50.0	33.3	16.7
5.89	2.945	99.5	49.8	33.2	16.6
5.90	2.950	99.2	49.6	33.1	16.5
5.91	2.955	98.8	49.4	32.9	16.5
5.92	2.960	98.4	49.2	32.8	16.4
5.93	2.965	98.0	49.0	32.7	16.3
5.94	2.970	97.7	48.8	32.6	16.3
5.95	2.975	97.3	48.7	32.4	16.2
5.96	2.980	96.9	48.5	32.3	16.2
5.97	2.985	96.6	48.3	32.2	16.1
5.98	2.990	96.2	48.1	32.1	16.0
5.99	2.995	95.9	47.9	32.0	16.0
6.00	3.000	95.5	47.7	31.8	15.9