

Caution: Prevent liquid from getting into edge finder to damage electronics

2. The shank is electrically conducted to the metal workpiece through the chuck and table, the LED lights up, when the ball touches the workpiece gently(fig.2). Right now, the distance between edge finder axis and metal workpiece surface is $5\pm 0.01\text{mm}$.

Caution: When fastly move the edge finder to the LED lights up, please make a slight back to the lights out, and then slowly move to the lights up, to ensure accuracy.

- 1-Contact ball(SØ10mm)
- 2-LED light
- 3-Shank

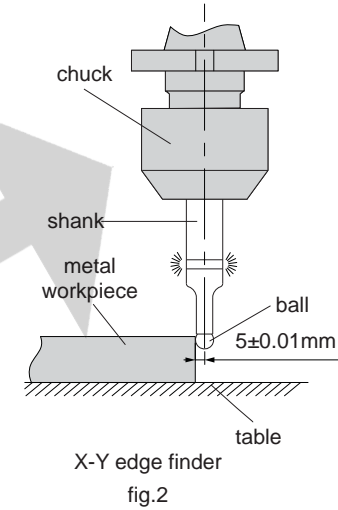

1. Put one battery(A23S, 12V) in, the positive side of battery should face up(fig.1). Confirm the lighting of LED light with connecting contact ball and shank with a metal material.

3. Not suitable for rotary use.

