

Caution: Prevent liquid from getting into edge finder to damage electronics

- 1-Contact ball(SØ10mm)
- 2-LED light
- 3-Beeper
- 4-Shank
- 5-Battery cover

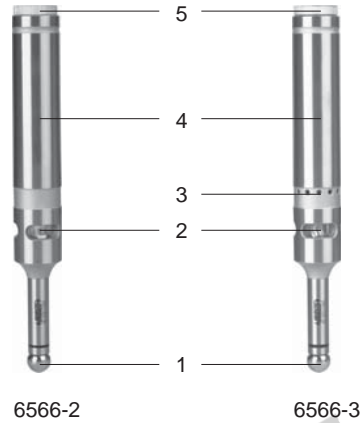

1. Put one battery(23AE, 12V) in, the negative side of battery should face up(fig.1). Confirm the lighting of LED light and the sounding of beeper(6566-3) with touching A-B part with a metal material(fig.2).

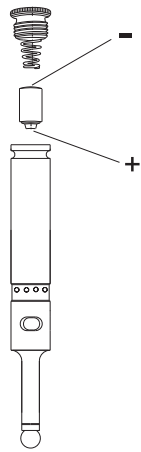

fig.1

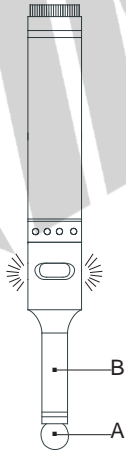

fig.2

2. The shank is electrically conducted to the metal workpiece through the chuck and table, the LED lights up and the beeper(6566-3) sounds, when the ball touches the workpiece gently(fig.3). Right now, the distance between edge finder axis and metal workpiece surface is $5\pm 0.005\text{mm}$.

Caution: When fastly move the edge finder to the LED lights up, please make a slight back to the lights out, and then slowly move to the lights up, to ensure accuracy.

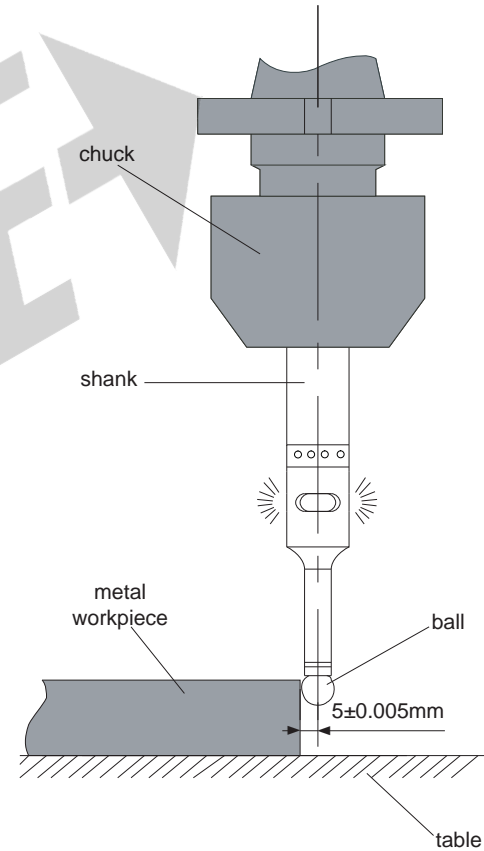

fig.3

3. Not suitable for rotary use.