



OPERATION INSTRUCTION

Welding Gage Code 4840-1



使用说明书

4840-1 焊接规

Graduation	Accuracy
0.2mm	±0.1mm

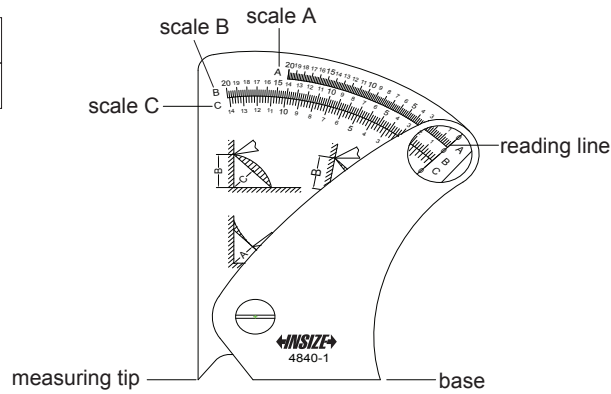

分度值	精度
0.2mm	±0.1mm

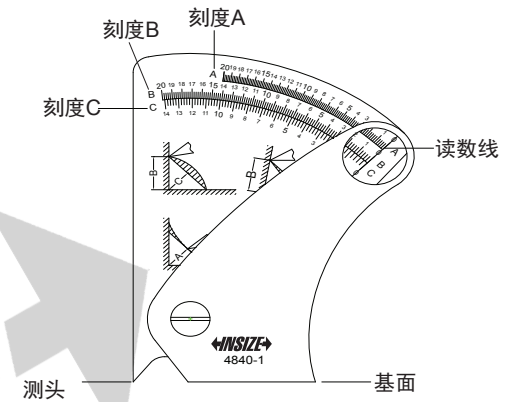

Measuring purpose

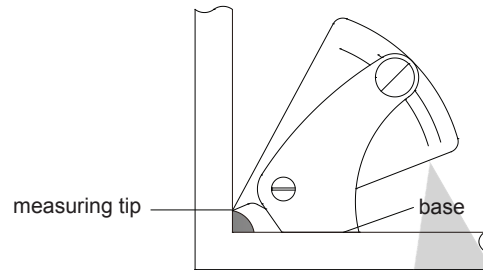

测量方法:

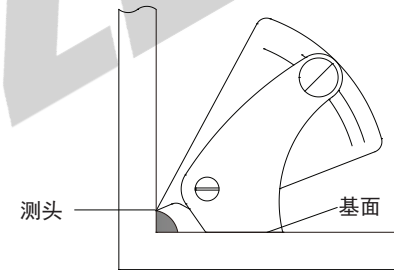

Reading: A means scale A, B means scale B, C means scale C

读数: 图示尺寸A、B、C分别对应刻度A、刻度B、刻度C读数

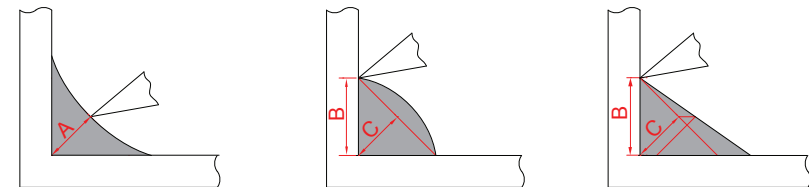
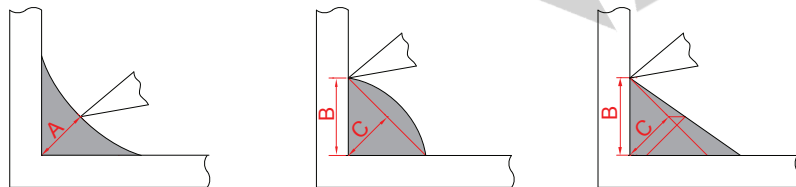

MN-4840-C/E

V0

MN-4840-C/E

V0