

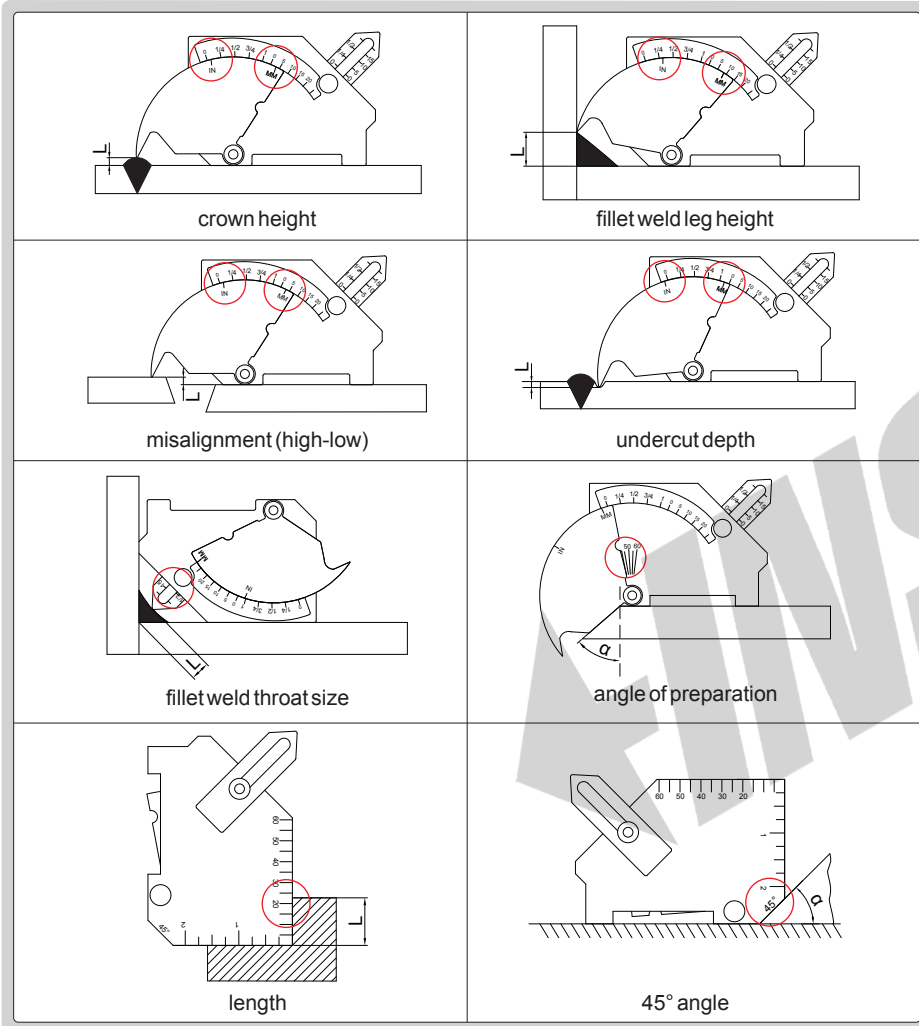

# OPERATION INSTRUCTION

Welding Gauge  
Code 4835-1



Measurement	Range	Graduation	Accuracy
crown height	0-25mm (0-1")	1mm (1/16")	±0.5mm
fillet weld leg height	0-25mm (0-1")	1mm (1/16")	±0.5mm
misalignment (high-low)	0-25mm (0-1")	1mm (1/16")	±0.5mm
undercut depth	0-2mm (0-1/8")	1mm (1/16")	±0.5mm
fillet weld throat size	0-20mm (0-3/4")	1mm (1/16")	±0.5mm
angle of preparation	0-60°	5°	±1°
length	0-60mm (0-2")	1mm (1/16")	±0.5mm
45° angle	—	—	±1°

MN-4835-1-C/E