

Back Plunger Long Styli Dial Test Indicator 2899-05

Range: 0.5mm
 Graduation: 0.01mm
 Accuracy: 13μm
 Hysteresis: 3μm

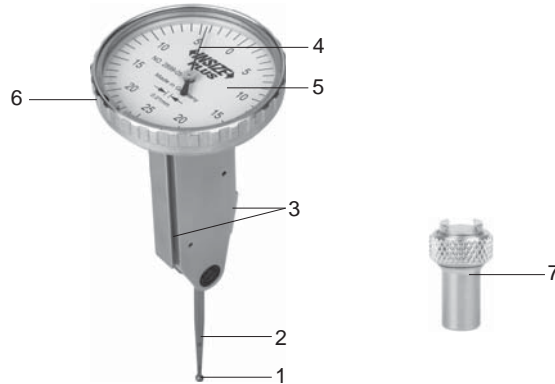

- 1-Carbide contact point
- 2-Styli
- 3-Dovetail groove
- 4-Needle
- 5-Dial face
- 6-Bezel
- 7-Clamp(diameter Ø8mm)

Caution: ---Prevent dust or liquid from getting into dial test indicator through the groove, otherwise the internal gear will be seized up(fig.1)
 ---Avoid the impact of the styli

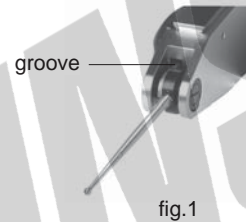

1. The product with antimagnetic body has ceramic bearing.
2. Dial test indicator should be fixed firmly to use. It can be fixed by dovetail groove directly (fig.2), also can be fixed by clamp(fig.3).



3. During measurement, styli should be vertical to measuring direction (fig.4). When the styli is at an angle with the measuring direction (fig.5), the following correction should be made.

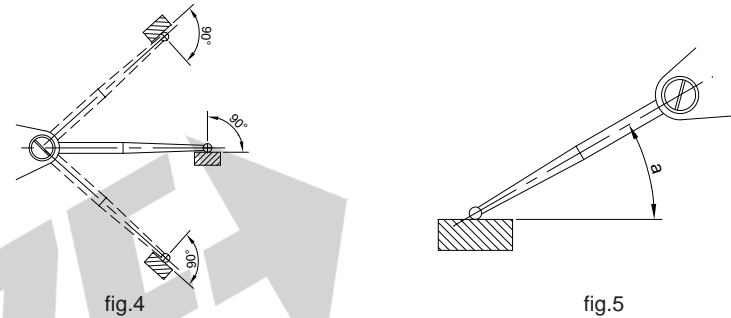

Angle α	10°	20°	30°	40°	50°	60°
Correction	0.985	0.940	0.866	0.766	0.643	0.500

For example: Angle α is 10°, the correction is 0.985, if the reading is 0.15mm, then:
 True value = 0.15mm × 0.985 = 0.148mm

4. Each type of dial test indicator has specific length of styli (L, fig.6). If the length is not correct, measurement error will result. Please refer to the following table to choose correct styli.

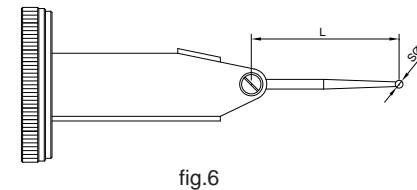

Code	For dial test indicator	Material of contact point	L	D
6284-51	2899-05	carbide	38.2	SØ1
6284-52		carbide	38.2	SØ2
6284-53		carbide	38.2	SØ3
6284-55		ruby	38.2	SØ2