

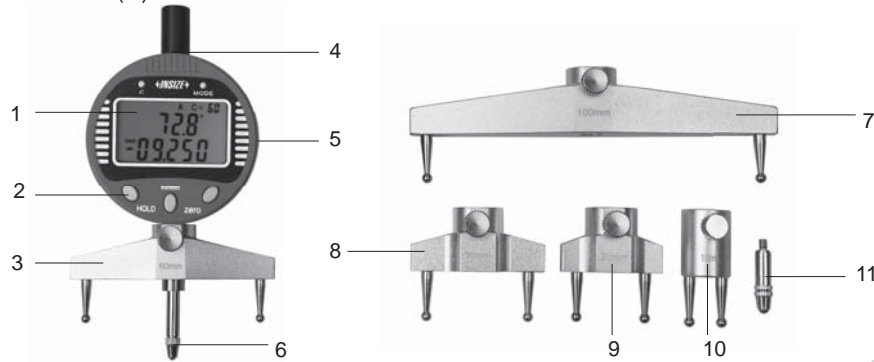

OPERATION INSTRUCTION

Digital Radius Gauge Code 2183

Resolution: 0.005mm/0.00005"
Accuracy: $\pm 0.01R$ (R is the radius to be measured)
Range of radius (R): 5-700mm/0.2-27.5"



- 1- LCD display
- 2- Buttons
- 3- Measuring jaw C=60mm
- 4- Battery cover
- 5- Data output
- 6- Measuring tip
- 7- Measuring jaw C=100mm
- 8- Measuring jaw C=30mm
- 9- Measuring jaw C=20mm
- 10- Measuring jaw C=10mm
- 11- Lengthening measuring tip

1. The gauge can be used to measure radius(R1, R2), angle A and chord height C of internal and external arcs(fig.1). The display as fig.2.

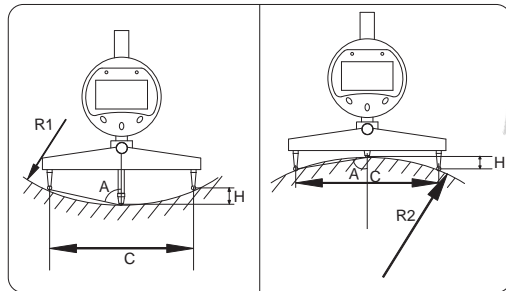

fig.1

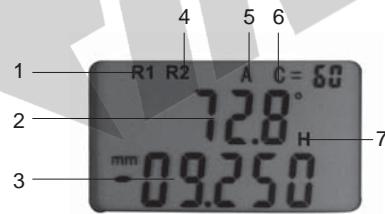
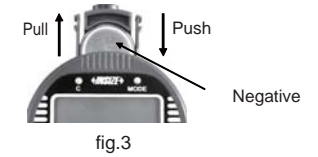

fig.2

- Display:
- 1. R1 means internal arc measurement
 - 2. Radius of arc in "R1" or "R2" mode, or angle in "A" mode
 - 3. Chord height H
 - 4. R2 means external arc measurement
 - 5. Angle measurement mode
 - 6. C is the selected measuring jaw
 - 7. Reading hold mode

2. Please prevent liquid from getting into the gauge to damage electronics.
3. Install and remove battery(CR2032), the negative side of battery should face out(fig.3).



4. Buttons:
Long press: longer than 2 seconds; short press: less than 2 seconds.
ZERO---When display is powered off: short press to turn on display; when display is powered on: short press to set zero, long press to turn off display.
in/mm---Short press for mm and inch conversion.
HOLD---Short press it to keep the reading and "H" appears. Short press it again to exit.
C---Short press it to select the measuring jaw.
MODE---Short press for "A" and "R" measuring mode conversion.

5. How to use
(1) Select the measuring jaws according to below table, then adjust the value of C which is on display, and to make it consistent with the measuring jaw.

Size of measuring jaws	Range of radius(R)	
	External arc measurement	Internal arc measurement
C=10	R5-R13mm	R6.5-R15mm
C=20	R11-R30mm	R14-R30mm
C=30	R22-R100mm	R27-R100mm
C=60	R94-R260mm	R94-R260mm
C=100	R255-R700mm	R255-R700mm

- (2) Set zero: Put the gauge on a plain surface and set zero(fig.4).
- (3) Put the gauge on an arc, "R1", "R2" or "A" will be displayed automatically.

Caution: During measurement, please prevent measuring tip from being scratched or damaged. Do not operate abruptly, drop or strike the gauge.

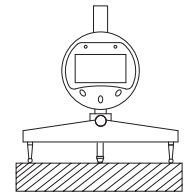

fig.4

6. If there is nothing on display or digits blurring, battery voltage is too low, please replace battery. If digits do not change when buttons are pressed or measuring tip is moved, take out battery and put it back after 1 minute. Remove battery if the gauge is not to be used for a long period of time.
7. Working temperature is 0-40°C/32-104°F, relative humidity should not exceed 80%.

MN-2183-C/E